

Electronic Wallpaper

Carol Bales, Jon Drews, Matt Lee
85 East 5th Street
Suite 423
Atlanta, Georgia, 30318

ABSTRACT

This research explores the properties of thermochromic ink and conductive materials for use in manufacture of an ambient information display. A wall-mountable poster-sized display was created for use in the home to display information useful in preparation for the day. The prototype display has thermochromic ink on paper and conductive traces affixed to the back. The traces are wired to a microprocessor that converts power to heat, and controls activation of each “pixel” of data. A software interface imports data feeds for Weather, Schedule and Temperature. The final prototype is remarkably thin and reasonably inexpensive and warrants further investigation as a manufacturable product.

ACM Classification: H5.2 [Information interfaces and presentation]: User Interfaces. - Prototyping

General terms: Design, Human Factors

Keywords: Ambient Information System, Ubiquitous Computing, Thermochromic Ink

INTRODUCTION

This project explored thermochromic ink and conductive materials and their suitability for creation of a manufacturable, ambient information system. An initial phase of research focused upon materials exploration necessary to create a single 1.25” “pixel” controlled by a processor and power source that would generate sufficient heat to activate the thermochromic ink. Follow up research explored how to create a multi-pixel display using real-time data. In order to ensure that the final product was suitable for manufacture, several constraints were maintained such as product thickness, modular design, low cost and household safety.

RELATED WORK

Thermochromic ink has been used in other related projects, but with varying levels of documentation. Related projects include creation of an “Animated Quilt” using conductive thread, fabric and thermochromic ink (Berzowska & Bromley, 2007), and a digital wall display (Buzzini, 2005 and Nastypixels.com). The digital pixel display is documented via a patent, the legalese making it problematic as a source of information. Blumen Wallpaper (Loop.ph, 2004) uses a series of electronically activated shapes. The shapes are configured to react to various sensors and convey meaning,

however there is little documentation on materials or procedures.

PHASE 1 SUMMARY

In the first phase we explored the properties of thermochromic ink, conductive materials, and base materials to create a base unit “pixel”. Materials were examined individually and in combination in order to yield the best combination of materials and application methods.

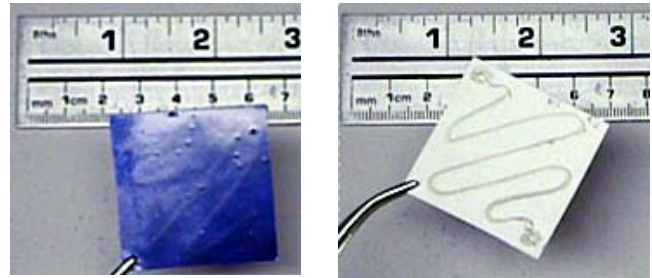

Figure 1: Showing front and back of prototype pixel

Base Unit Pixel Specifications

Pixel size	1.25”
Thermochromic ink	87.8°F activation ink
Base material	Coated paper stock
Conductive trace	Silver conductive pen
Voltage and current to “activate” pixel	1.5V, .14A
Reaction at 87.8 degrees Fahrenheit	Immediate
Time to return to cold state	3-5 minutes

Materials & Construction

Thermochromic ink allows for an electrically controlled visual change in the device. It is applied on the surface of a base material and can be used in layers with other paints and inks to produce different visual effects. Thermochromic inks use leuco dyes that change their visual property with changes in temperature. The inks start in a “cold color” i.e. the ink in its non-activated state. The “hot color” refers to the color of the ink when the temperature is raised to a predetermined activation point. A conductive material is used to convert power into heat, which is then transferred to the thermochromic ink. The conductive trace

is affixed to the back of the paper on which the thermochromic ink is applied.

Powering the Pixel

Current sourcing for each standard digital I/O pin was found to be 10mA. This was hooked up to a test pixel and a gradual color change was seen (See Figure 2). Initial tests showed that a pixel could be powered by using a Sanguino microprocessor alone, however it was determined that there was a need to find better ways to control the current and voltage.

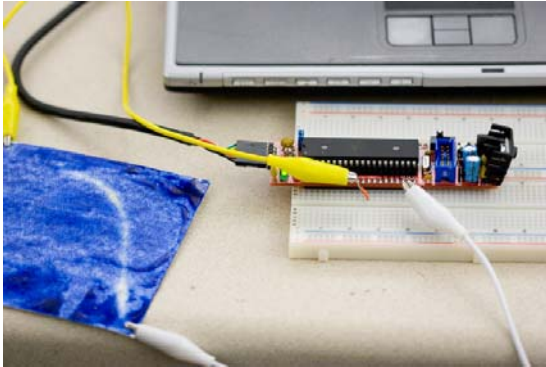

Figure 2: A prototype pixel heated by a Sanguino processor.

PHASE 2 RESEARCH SUMMARY

In the second phase, we created a real-time display containing thirteen active pixels. Each of the pixels was wired to a microprocessor that controls its activation by sending power to the conductive trace, heating the thermochromic ink. We wrote software to connect the microprocessor controls to real-time data through a laptop. The main challenge was to fine tune the resistance of the conductive traces. Traces were created with a silver conductive pen and with nickel conductive spray. Due to its higher resistance, the nickel proved more effective with a 9V power source. The resistance of the pixels ranged from 70 to 190 ohms. They were activated with a current of .05 to .07 amps at 9V.

Concept

An ambient display serves as both visual design and real-time information display. The final application concept is a display that shows information helpful to the user in preparation for the day: Weather, Temperature and Personal Schedule. In its cold state, the display is decorative in nature; as it is activated, it morphs into an information display. In this example of “calm technology,” we created a visual design, and converted the “pixels” to design shapes. After consulting with Brewster Home Fashions about creation of an electronic wallpaper product, it was determined that a poster size display of 36” x 28” was a reasonable size.

The data is presented in an array of “pixels” dedicated to specific content (for example, weather). Each state of the weather is represented with a single pixel. Hardware constraints indicated a limit of 40 pixels for ease of implemen-

tation, so the final design prototype was designed for 25 pixels of which 13 are active.

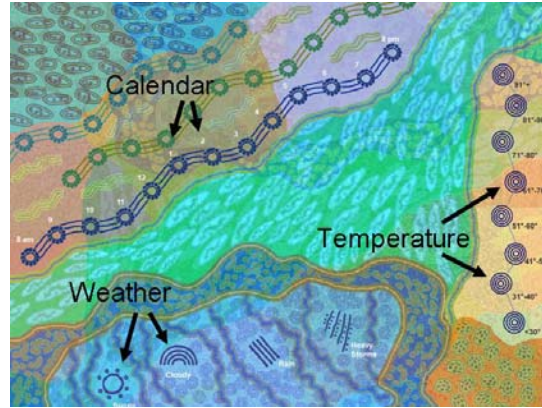

Figure 3: Calendar, Temperature and Weather were displayed in arrays.

Real-time Data Presented

Subject	Total Pixels	Data Points	Source
Schedule	13	8 am, 9, 10, 11, 12 pm, 1, 2, 3, 4, 5, 6, 7, 8 pm	Hardcoded temporarily in Java
Weather	4	Sunny, Rain, Storms, Cloudy, Heavy	XMLfeed from weather.com
Temperature	8	<30° Fahrenheit, 31-40, 41-50, 50-60, 61-70, 71-80, 81+	XMLfeed from weather.com

Ambient Display Design Criteria

An important aspect of the design is to integrate the display into a person’s surroundings, thus minimizing intrusiveness. The system was designed around the following criteria (Mankoff, et al. 2003):

- Display of useful and relevant information
- A non-intrusive/peripheral nature of the display
- A balance between aesthetics and environment
- Sufficient information display
- Visibility of state

Control

A Sanguino microprocessor platform was used to control the pixel display by using serial outputs to shift registers. A separate power source was used since the pixels require a certain amount of current and voltage. Higher currents and voltages will reduce the activation time of the pixel. The upper limit of current and voltage is pixel burnout, or where the paper, conductive ink, or thermochromic ink becomes too hot and loses functionality.

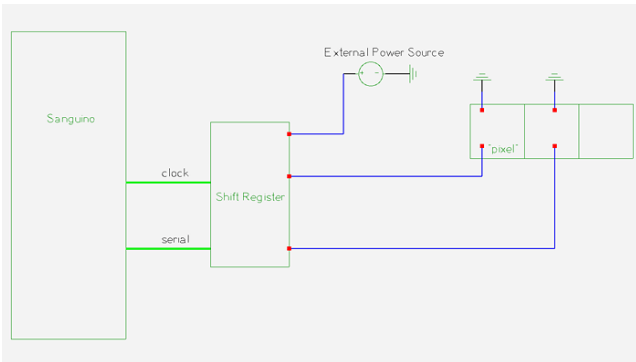

Figure 4: High level schematic of the controlling circuit for the display.

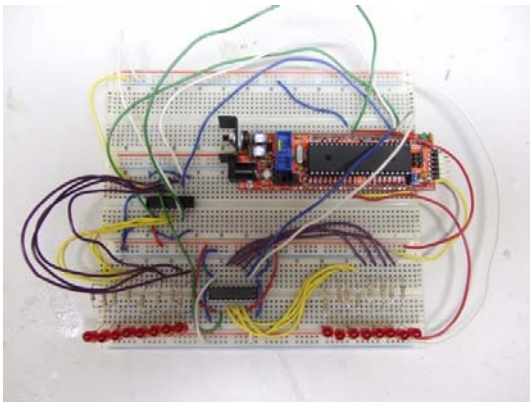

Figure 5: Testing board used to confirm outputs were working correctly. LEDs were then replaced with leads to the traces on the display.

The power source is used in conjunction with a power shift register, TPIC6595, to digitally control power to the pixels, or the on/off state. The TPIC6595 IC contains the standard shift register, 74HC595, but includes DMOS transistors at the end of the outputs so that a high power source (45V max, 250mA max) can be routed to the loads (in our case, “pixels”).

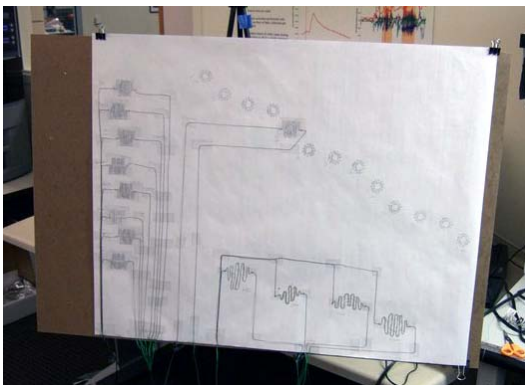

Figure N: Back of poster showing conductive traces and wiring behind “pixel” arrays.

Each output from the shift register was wired with 28 gauge standard insulated wire to the edge of the display and then connected to conductive thread. The conductive thread was adhered to the edges of each pixel trace using

conductive epoxy. The conductive thread was used behind the display since its smaller gauge is much less noticeable when mounted on a wall. The higher resistance of the conductive thread is negligible when compared to the resistance of the traces. Conductive traces were created separately and adhered to the back of the poster in the location of the thermochromic ink pixels.

Creating Software Interface & Data Feeds

This prototype display conveys schedule, daily weather conditions, and the current temperature. A program was coded in Java in which a laptop connects to www.weather.com. This program downloads an XML feed provided by the website, then parses it and reads the current temperature and weather condition. Having read the temperature and condition, the program then communicates with the Sanguino microprocessor via USB cable and specifies which pixels on the display to activate. Note that this requires internet access as well as a power source beyond that provided by the USB cable to the Sanguino. As long as the program is running, the information being shown on the ambient display will be up-to-date.

Additional Materials Research

Conductive materials

Our initial materials research created a working prototype with conductive ink used for repairing circuit boards. During the process of converting the pixel to a display, we realized that 1.5v and 0.14 amps per “pixel” is not very practical. When the pixels are hooked up in parallel, the voltage would stay at 1.5v but the current would increase to $0.14 * N$ amps where N is the number of “pixels”. This kind of power source is not very common. Given the conductive materials, the main challenge was to fine-tune the resistance of the conductive traces. We found that nickel spray was a better solution due to its higher resistance. Resistance of the smaller traces ranged from 70-190 ohms as opposed to ~10 ohms for the silver conductive trace. This enabled the device to be run at higher voltages, 9 volts, and draw less current (.05 - .07 amps) while still maintaining the same power drop over the trace.

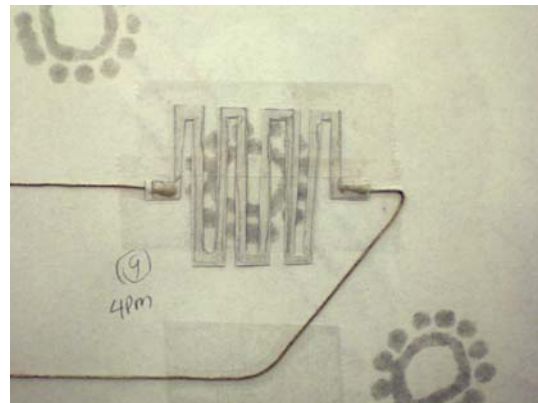

Figure N: Detail of a conductive trace using nickel conductive spray adhered to the back of a “pixel” and wired using conductive thread.

The area covered by the trace, and in effect the length of the trace affects the resistance of the trace. When the resistance of the trace becomes too high, current will decrease causing a smaller amount of power to drop across the trace, which causes a slower heating. Two sizes of pixel areas were created for the display, larger pixels for weather (app. 2.25" x 2.25") and smaller pixels for temperature and calendar (1.5" x 1.5"). Traces constructed with nickel conductive spray were deemed insufficient for the larger pixels because the resistance was too high and did not heat the larger pixel to the activation temperature of 87.8°F. To solve this we used conductive ink and increased the trace length to increase resistance. See Appendix B for specifications and characteristics of the nickel spray and conductive ink.

Activation of the pixel is affected by several factors:

- Thermochromic ink activation temperature
- Ink thickness and uniformity
- Paper thickness
- Trace thickness and uniformity
- Trace material, area and shape
- Room temperature
- Voltage
- Wall surface temperature

Thermochromic ink

The method for applying thermochromic ink directly affects the thickness of the ink and therefore the time to visible change, with thicker ink resulting in a slower visible change while at activation temperature. For this prototype, ink was applied by brush and squeegee using stencils for the specific shapes. Additional methods for application including airbrush and silk screen should be researched further to find the best application method for the thermochromic ink. Additionally, initial tests on a new quantity of water-based thermochromic ink show that it is significantly easier to apply thinly and to clean.

MANUFACTURING POSSIBILITIES

There are several factors to consider when working with these materials, and fall into the basic categories of Manufacture, Safety, Hardware, and Materials constraints.

Manufacture

- Simplicity of implementation
- Thinness of display (as wallpaper)
- Design
- Modularity (the ability to change out poster and hardware separately)
- Printing and application methods

Safety

- Current and voltage should not exceed 15V to protect humans in case of contact
- Excessive temperatures cause safety issues with the potential of inflaming the paper

Electronics

- The Sanguino microprocessor platform is limited to a sourcing current of 10mA

- Sufficient power source for number of pixels
- Hardware cost

Materials

- The conductive material could be “burned out” with too high a current
- Materials cost
- Speed of activation of the display (pixel turn on/off)
- Susceptibility to UV radiation
- Durability of the conductive traces & wiring
- Limitations to color variations and effects

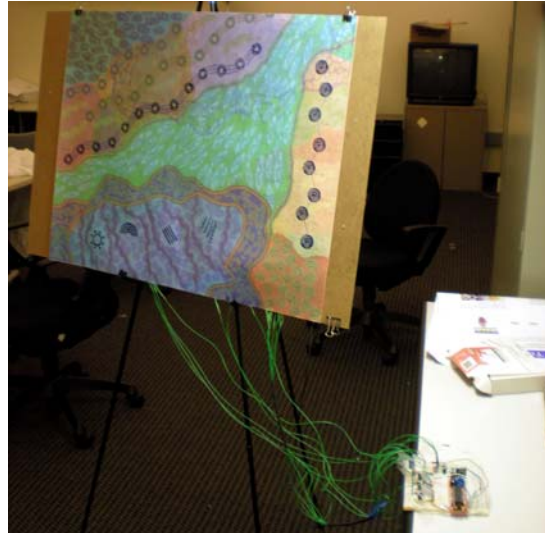

Figure 3: Phase 2 poster wired to processor and power source.

CONCLUSION

Our research indicates that these materials are highly flexible and may be suitable for manufacture of an inexpensive, ambient information system. Further research should be done to determine how to create multiple conductive traces with a consistent resistance, and to combine the components in a commercially suitable package.

ACKNOWLEDGMENTS

The researchers would like to thank Citi Inks and Brewster Home Furnishings for supplying ink and paper materials.

REFERENCES

1. Berzowska & Bromley, XS Labs 2007, <http://www.xslabs.net/papers/iffi07-berzowska-AQ.pdf>
2. Buzzini, 2005, <http://www.wipo.int/pctdb/en/wo.jsp?IA=IB2004003294&WO=2005093496>
3. Not So White Walls video: <http://www.nastypixel.com/prototype/not-so-white-walls>
4. Loop.ph 2004, Blumen Wallpaper: <http://www.loop.ph/bin/view/Loop/BlumenWallpaper>
5. Mankoff, J., et al., *Heuristic evaluation of ambient displays*, in *Proceedings of the SIGCHI conference on Human factors in computing systems*. 2003, ACM: Ft. Lauderdale, Florida, USA.

APPENDIX A: PHASE ONE CONDUCTIVE MATERIALS DATA

Original Mixes of Conductive Ink

Mix	Ingredients	Conductive?
#1	Mix 1.5 part graphite to 1 part Liquid Tape to 1 part Tuloul by volume.	No
#2	Mix 1.5 part graphite to 1 part Liquid Tape to 3 parts Tuloul by volume.	No
#3	Mix 1.5 graphite to 1 part liquid tape	No
#4	Apply graphite to paper, then put liquid tape over graphite, smooth over	No
#5	Apply graphite to paper, put liquid tape over graphite, smooth using spoon	No
#6	Apply 1.5 part graphite to 1 part amazing goop	No
#7	Apply 1 part contact cement to 2 parts graphite	Yes
#8	Apply 1 part amazing goop to 2 parts graphite	Yes
Fine Grain J	Applied contact cement with graphite mixed in onto paper	Yes
Fine Grain M	Applied contact cement to paper, stamped graphite in	Yes

Conductivity, Resistance and Voltage

Type of Conductive Ink	Resistance	Current at Change in Thermo-chromic Ink	Voltage at Change in Thermo-chromic Ink
Mix #7	~450 ohms	0.02 A	7.8V
Fine Grain J	~4000 ohms	0.03 A	11.4V
Fine Grain M	~10000 ohms	0.01 A	12.4V
Leaf Self Ink	~16000 ohms		
Leaf Silver Ink	21.5 ohms	0.07A	0.7V
1st Squeegee	~800 ohms	0.02 A	2.9V
2nd Squeegee	~1200 ohms		
Graphite HB	~43000 ohms		

APPENDIX B: PHASE TWO CONDUCTIVE MATERIALS DATA

Conductivity and Resistivity – comparison of Nickel Spray and Silver Conductive ink

	Nickel Spray (2 coats) Trace Size- 2.6mm	Silver Con- ductive Ink Trace Size- 1.7mm
Resistance per trace (trace size XXX)	6.5 ohms	1.1 ohms
Resistance per 2*(trace size)^2 in linear order	7.6 ohms	1.1 ohms
Resistance per 4*(trace size)^2 in linear order	11 ohms	1.6 ohms

Nickel Spray Brand Name: MG Chemicals, Super Shield Nickel Conductive Coating

Silver Conductive Ink Brand Name: Trace Technologies, Conductive Pen, 2505-N

Pixel-based Measurements

Test pixel was a sample from the array of weather temperatures (<30°F)

Conductive Trace	
Resistance of trace measured	203.3 ohms
Length of trace	207.4mm
Area (cm^2) the trace is contained in	1360.9 mm2
Trace properties	nickel spray radiator design, square turns
Number of turns	7 corners,
Length of each leg	31.7mm edge to edge
Distance between each leg	1.5 - 3.4mm

Conductive Thread, Paper, Ink	
Length of connecting conductive thread	34.15cm
Resistivity of conductive thread	1.4 ohm/cm
Properties of the thermochromic ink (activation temp, serial number)	CTI DynaColor Thermochromic Wet Offset 5BOXX31B0103, Cold Color Blue, Warm Color Colorless, Clearing Temp: 31C
Approximation of thermochromic ink thickness	less than 0.025mm

Paper properties (type, coating)	
Paper thickness approximation	less than 0.025mm

Activation Temperatures	
Voltage and current for activation	9V and 0.04 Amperes
Time to first visible change in thermochromic ink from cold state to warm state	1 second
Time to majority change in thermochromic ink from cold state to warm state	10 seconds
Temp: off	74.5 F
Temp: on activation	76 F
Temp: 1 sec	77F
Temp: 2 sec	79.5F
Temp: 4 sec	80F
Temp: 6 sec	84F
Measured thermochromic ink change (verify the activation temperature)	
First time and temp at visible change	77F @ 1 second
First time and temp at majority change	90F @ 10 seconds
First time and temp at full change	92F @ 1 minute 35 seconds

Deactivation Temperatures	
Time to return from warm state to cold state	1 minute 35 seconds
From full activation temperature (31° Celsius, temp upon cooldown)	
Temp/Activation State: 3 sec after heat shut off	90.5F
Temp/Activation State: 10 sec after heat shut off	84.5F
Temp/Activation State: 20 sec after heat shut off	80F
Temp/Activation State: 60 sec after heat shut off	76.5F
Temp/Activation State: 2 minutes after heat shut off	76F
Temp/Activation State: 3 minutes after heat shut off	76F
	(example: 78 F / fully returned to

	cold state)
--	-------------

APPENDIX B: Videos

Phase 1:

<http://www.youtube.com/watch?v=zO7UkMGLsK8>

<http://vimeo.com/1902410>

Phase 2:

<http://www.youtube.com/watch?v=EepbAt9BJdg>